

Filtro

Filtro Y (Inox 304 / 316)



316 BSP	304 BSP	MACHO X FÊMEA
304Y04G	316Y04G	1/2"
304Y06G	316Y06G	3/4"
304Y10G	316Y10G	1"
304Y12G	316Y12G	1 1/4"
304Y14G	316Y14G	1 1/2"
304Y20G	316Y20G	2"

CARACTERÍSTICAS
AS ROSCAS ESTÃO CONFORME:
ASME B1.20.1 (NPT)
DIN 2999& BS 21
ISO 228/1 & ISO 7/1
MÁX. TEMPERATURA: 229°C
PRESSÃO DE TRABALHO: 800 PSI

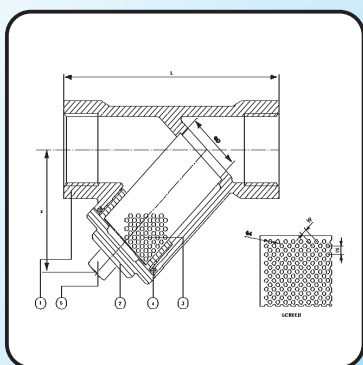

DIMENSÕES					
NPS	L	H	D	d	W
1/4"	2.24	1.38	0.39	0.04	0.08
3/8"	2.24	1.38	0.39	0.04	0.08
1/2"	2.36	1.5	0.59	0.04	0.08
3/4"	2.72	1.65	0.79	0.04	0.08
1"	3.35	1.97	0.98	0.04	0.08
1 1/4"	3.9	2.17	1.26	0.04	0.08
1 1/2"	4.37	2.32	1.5	0.04	0.08
2"	5.39	1.87	2	0.04	0.08
2 1/2"	6.77	3.58	2.56	0.04	0.08
3"	8.07	4.33	3.15	0.04	0.08

**OBS.: PADRÕES APLICÁVEIS
TESTE E INSPEÇÃO API 598**

ITEM	PARTES	MATERIAL	
1	CORPO	ASTM A351 - CF08 / 1,4408	ASTM A276 - 316
2	CAPA		
3	SCREEN	AISI 316	
4	JUNTA	PTFE	
5	PLUG	ASTM A351 - CF8M / 1,4408	

Filtro

Filtro Y



MODELO	ROSCA	TEMPERATURA	PRESSÃO	SECÇÃO MALHA
VY04	G1/2	0-65°C	16 BAR	0,65MM2
VY06	G3/4	0-65°C		
VY10	G1	0-65°C		
VY14	G1 1/2	0-65°C		
VY20	G2	0-65°C		

OBS.: MATERIAL DO CORPO-LATÃO, MATERIAL DA MALHA-AÇO INOX.